



## PRODUCT SPECIFICATION

### Lithium Iron Phosphate Battery

Model: FEV10050150SH20

Received Marking	
Customer's Name	: _____
Signature	: _____
Company Stamp	: _____

Prepared by	Checked by	Approved by



**1. Scope**

This specification is applied to FEV Lithium Iron Phosphate Battery manufactured by Falcon EV company Ltd.

**2. Product and Model**

2.1 Product : Lithium Iron Phosphate Battery

2.2 Model : FEV10050150SH20

**3. Ratings**

Item		Rating	Note
3.1 Capacity	Nominal	5100mAh	Standard charge, 1.0C discharge, 2.3V/cell cut off
	Minimum	4990mAh	
3.2 Nominal Voltage		3.2V	Average voltage at 1.0C discharge
3.3 Standard Charge Condition		0.5C(2550mA),3.65V(CC-CV), 2.5h	
3.4 Maximum Charge Current		1C(5100mA)	
3.5 Maximum Charge Voltage		3.65V	
3.6 Maximum Discharge Current		20C(102.0A)	Continuous Current
3.7 Discharge Cut-off Voltage		2.3V	
3.8 Voltage as of shipment		3.1~3.2V	
3.9 Cell Weight		Approx.138.5g	
3.10 Operating Temperature	Charge	0~45°C	90%RH Max.
	Discharge	-20~60°C	90%RH Max.
3.11 Storage Temperature	1 month	-20~45°C	Recommended storage temperature: 20°C or less, at the shipment state
	3 month	-20~35°C	
	1 year	-20~20°C	

**4. Outline Dimensions and Appearance**

4.1 Outline Dimensions

See attached drawing for FEV10050150SH20(Fig.1).

Thickness : Max. 9.7mm (Measured with weighting 300gf at 23±2°C)

Width : 50.5±0.5mm (measured with weighting 300gf at 23±2°C)

Length : 152.0±1.0mm (without lead film)

This thickness will be swelling when high temperature storage or operation in high temperature.

3.65 Appearance

There shall be no such defect as remarkable scratches, breaks, crack, discoloration, leakage, or deformation, which may adversely affect commercial value of the cell.



## 5. Performance

### 5.1 Standard Test Condition

Test should be conducted with new batteries within one month after shipment from our factory and the cells shall not be cycled more than five times before the test. Test condition shall be at  $23\pm 2^{\circ}\text{C}$  and  $65\pm 20\%\text{RH}$  as long as there is no doubt. The humidity can be any condition unless it affects the test results.

### 5.2 Measuring Instrument or Apparatus

#### 5.2.1 Dimension Measuring Instrument

The dimension measurement shall be implemented by instruments with equal or more precision scale of 0.01mm.

#### 5.2.2 Voltmeter

Standard class specified in the national standard or more sensitive class having inner impedance more than 10 M $\Omega$ /V

#### 5.2.3 Ammeter

Standard class specified in the national standard or more sensitive class. Total external resistance including ammeter and wire is less than 0.01 $\Omega$ .

#### 5.2.4 Impedance Meter

Impedance shall be measured by a sinusoidal alternating current method (1kHz LCR meter).

### 5.3 Standard Charge Definition

Standard charge is defined by charging for 2.5hrs at 3.65V of constant voltage and 0.5C(2550mA) of constant current.

### 5.4 Rest Period

Unless otherwise defined, 10min rest period after full charge, 10min rest period after discharge.

### 5.5 Standard Discharge Definition

Standard Discharge is defined by discharging at 1.0C (5100mA) down to 2.3V.

### 5.6 Initial Performance Test

Item	Test Condition	Criteria
Open-Circuit Voltage	The open-circuit voltage shall be measured within 24 hours after standard charge.	3.1V or more
AC Impedance Resistance	The Impedance shall be measured in an alternating current method (1kHz LCR meter) after standard charge at $23\pm 2^{\circ}\text{C}$ .	3.0m $\Omega$ or less (bare cell)
Initial Capacity	The capacity on 1.0C(5100mA)discharge to 2.3V shall be measured after standard charge at $23\pm 2^{\circ}\text{C}$ .	5100mAh or more



5.7 Electrical Performance

5.7.1 Discharge Rate Capabilities

Discharge Capacity is measured with the various currents in under table and 2.3V cut-off after rated charge.

Discharge Current	1C(5100mA)	20C(102.0A)
Discharge Capacity	100%	85%

Note: Percentage as an index of the rated discharge capacity(=5100mAh) is 100%.

5.7.2 Temperature Dependence of Capacity (Discharge)

Cells shall meet the discharge capacity requirements listed in the below table under respective discharge temperatures. The capacities are to be measured with constant discharge current 5100mA (2.3V cut-off) after standard charge at 23±2°C.

Discharge Temperature	23°C	45°C
Discharge Capacity	100%	95%

Note: If charge temperature and discharge temperature are not the same, the interval for temperature change comes to 3 hours.

5.8 Safety Performance

Item	Test Condition	Criteria
Overcharge Test	After standard discharge, cells are charged at constant current of 10.2A and constant voltage of 5.0V while tapering the charge current. Charging is continued for 48 hours.	No explosion, no fire, no smoke.
Nail Test	A nail (diameter: 2.0mm) is penetrated vertically through the center of a fully charged cell and left for 6 hours.	No explosion, no fire, no smoke.

5.9 Mechanical Performance

Item	Test Condition	Criteria
Vibration Test	After standard charge, cells are to be tested as following conditions: Amplitude:0.8mm Frequency:10~55Hz(sweep:1Hz/min) Direction: X/Y/Z axis for 90~100min. The battery is to be tested in three mutually perpendicular to each axis.	No leakage or remarkable defective appearance.  Recovery Capacity ≥ 90% Initial capacity
Drop Test	Drop cells in the shipment condition (50% discharge)from 1.2m height onto 5cm or thicker concrete with p-tile on it 3 times each of X, Y, and Z directions at 23±2°C.	No leakage. Recovery Capacity ≥ 90% Initial capacity

6. Period of Warranty

The period of warranty is one year from the date of shipment. FEV guarantees to give a replacement in case of cells with defects proven due to manufacturing process instead of the customer’s abuse and misuse.



**7. Shipment**

Cells shall be shipped in 50% state of charge.

**8. Others**

Any matters that this specification doesn't cover should be conferred between the customer and FEV.

Fig.1 Dimensional Drawing of FEV10050150SH20

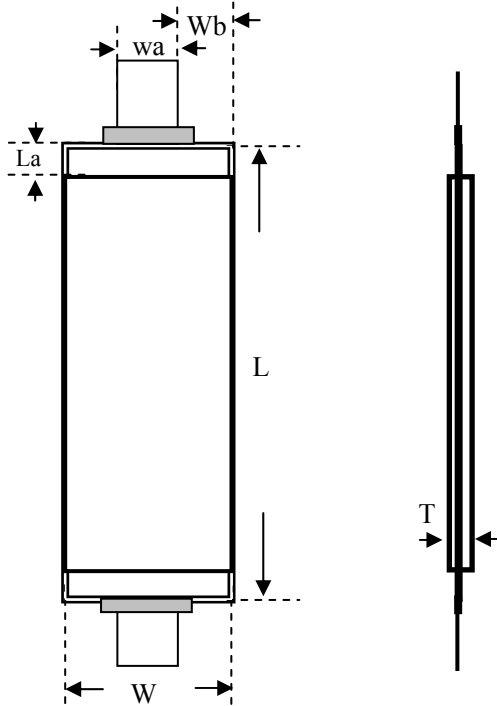

Item	Item
T	Max. 9.70 mm
W	50.5±0.5mm
Wa	20.0±0.1mm
Wb	12.0±0.5mm
L	152.0±1.0mm
La	5.0±0.2mm